

# UNIQUE

XTRA TUFF VICES

VICES

## UNIQUE TILT LOCK MACHINE VICE

KURT TYPE

SWIVEL BASE CODE NO. U350S

FIXED BASE CODE NO. U350



U 350 S

### FEATURES

- Fitted with Thrust Bearing for Smooth Movement
- UniqueTilt Lock Vices can with stand heavy jobs.
- Top & Bottom of vice bed, bottom & both sides of jaws & all jaw mounting surfaces are precision ground.
- By reversing the jaw plates the jaws are raised & can be fitted to both ends of the fixed jaws & the moveable jaws.
- The four different positions of jaw plates pair are available for more gripping area.
- Coolant through on vise body and swivel base.
- Chip clearance holes ..... no dead pockets.
- Swivel handle allows the screw head revolved on machine table.
- The vice can be disassembled and repaired by regrinding.
- Supplied with Stopper for Fast Production

### SPECIFICATIONS

	SIZE IN INCHES	4	5	6	8
A	Width of jaws in mm	100	125	150	200
B	Opening of jaws in mm	100	120	150	200
C	Depth of jaws in mm	40	40	45	60
D	Width Swivel Base in mm	225	270	310	410
E	Width Fixed Base in mm	175	205	220	310
F	Height Swivel Base in mm	140	145	170	220
G	Height Fixed Base in mm	100	100	125	160
H	Length overall in mm	345	375	460	595
	Tenon slot size in mm	16	16	20	20
	Weight (Approx) in kgs. Swivel Base	21	29	48	104
	Weight (Approx) in kgs. Fixed Base	16	21	35	74
2	Opening	150	170	215	300
3	Opening	230	250	310	400
4	Opening	270	295	370	492

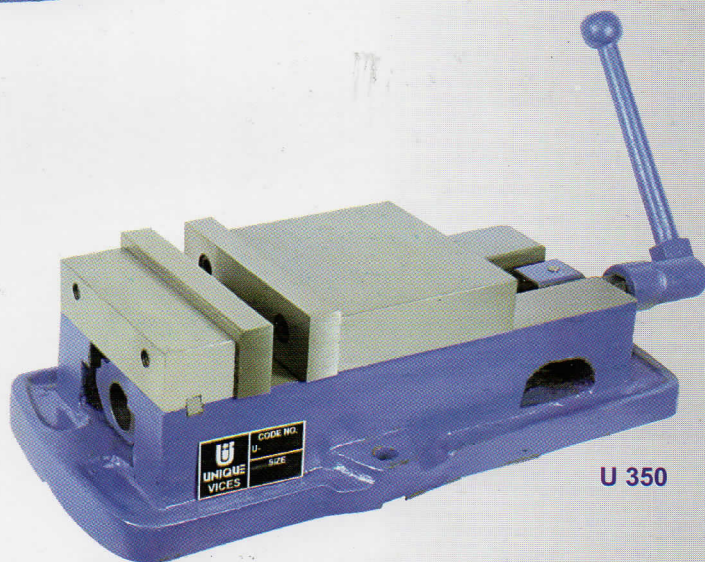

U 350

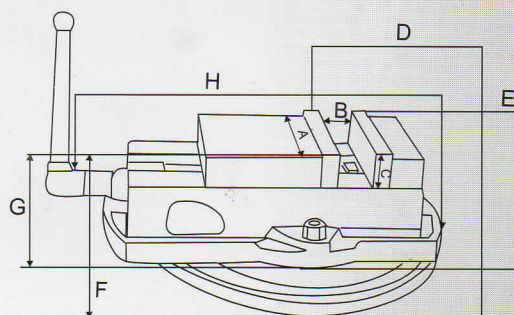

UNIQUE PROCESS MAKES THE UNIQUE VICES PRECISION AND STURDY